

Ecoflo® Biofilter – Concrete shell

Installation Guide – USA

This guide contains the information required to plan the installation of the Ecoflo® Biofilters STB-650B/BR-H1/H2/H3-A/NA (assembled and/or not assembled). The installation must be performed by an installer trained by Premier Tech Aqua. For more information, contact your local distributor or our customer service at 1 800 632-6356.

A) Ecoflo® Biofilters (Assembled: crushed stone and filtering media included)

Technical Data

Component materials for the concrete Ecoflo® Biofilter

- Shell and top tile: reinforced concrete 5000 PSI;
- Lids, main access, secondary access, ventilation system, access funnel, tipping bucket, central support, distribution plates and support rails: plastic;
- Filtering media: made of natural fibers.

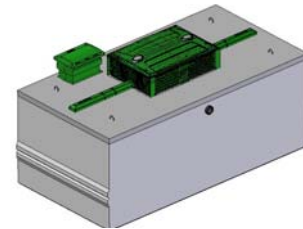

Connections

Flexible, watertight, and adapted to 4" Ø SDR-35 and SCH-40 PVC pipes. Outlet of the STB-650BR-H1 adapted to 1" Ø flexible pipes and STB-650BR-H2/ H3 adapted to 1½" Ø flexible pipes.

Dimensions

Caractéristiques	STB-650B/BR-H1-A	STB-650BR-H2-A	STB-650BR-H3-A
Weight of system (lbs)*	22,400	23,000	29,000
Volume of filtering media (ft ³)*	183	183	183
Length (L) (")	151 1/16	151 1/16	152 1/16
Width (W) (")	81 11/16	81 11/16	82 11/16
Height (h1) (")	61	68 1/8	80
Height (h2) (")	52 1/2	58 3/4	70 1/2
Height (h3) (")	49 3/8	56 1/2	68 1/4
Height (h4) (")	72 3/4	80	91 3/4

*Approximate : may vary.

Handling

2 hoisting grooves allow handling of the system with the proper hoisting equipment.

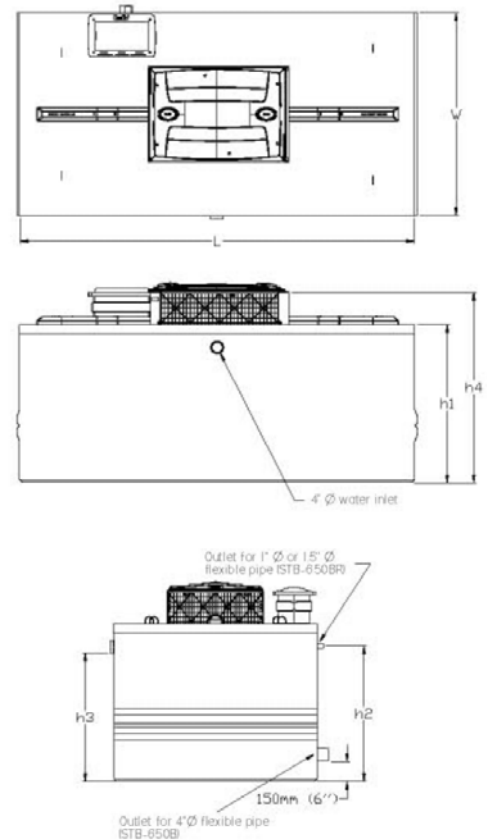

B) Ecoflo® Biofilters (Not Assembled)

Technical Data

Component materials for the concrete Ecoflo® Biofilter

- **Shell and top tile:** reinforced concrete 5000 PSI;
- **Lids, main access, secondary access, ventilation system, access funnel, tipping bucket, central support, distribution plates and support rails:** plastic;
- **Filtering media:** made of natural fibers.

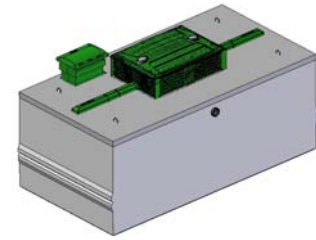

Connections

Flexible, watertight, and adapted to 4" Ø SDR-35 and SCH-40 PVC pipes. Outlet of the STB-650BR adapted to 1" Ø flexible pipes and for STB-650BR-H2/ H3 adapted to 1½" Ø flexible pipes.

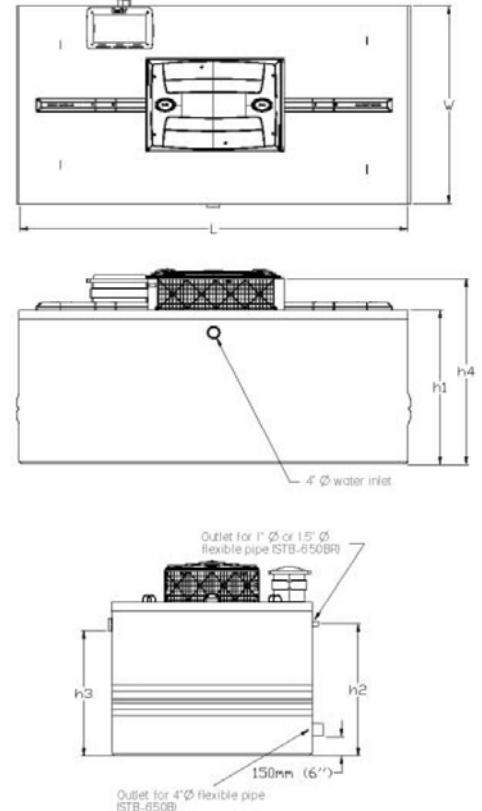

Dimensions

Caractéristiques	STB-650B/BR-H1-NA	STB-650BR-H2-NA	STB-650BR-H3-NA
Weight of the top tile (lbs)*	4,800	4,800	4,900
Weight of the shell (lbs)*	10,500	11,000	13,000
Volume of filtering media (ft³)*	183	183	183
Length (L)(")	151 1/16	151 1/16	152 1/16
Width (W)(")	81 11/16	81 11/16	82 11/16
h1 (")	61	68 1/8	80
h2 (")	52 1/2	58 3/4	70 1/2
h3 (")	49 3/8	56 1/2	68 1/4
h4 (")	72 3/4	80	91 3/4

*Approximate: may vary.

Handling

2 hoisting grooves allow handling of the system with the proper hoisting equipment. The shell and the top tile can also be moved separately with the 4 hoisting rings on the top tile, and 4 more rings inside the shell (model H1 only, on the bottom).

Ecoflo® Biofilters treatment efficiency (all models)

Parameters	Septic Tank Effluent*	Ecoflo® Biofilter Effluent**
Biochemical Oxygen Demand (BOD ₅)	≤ 250 mg/L	≤ 2 mg/L
Total Suspended Solids (TSS)	≤ 75 mg/L	≤ 2 mg/L
Fecal Coliforms (CFU/100 ml)	≤ 2 000 000 CFU/100 ml	≤ 948 CFU/100 ml

* Typical values according to sampling campaigns in Canada and United States since 1995. (80% of septic tank effluent samplings).

** Results obtained during ANSI/NSF Standard 40 certification testing period.

Installation procedure

1. System components description
2. Components location and special instructions
3. Determination of the effluent disposal method
4. Functions of the Ecoflo® Biofilter
5. Installation sequence
6. Typical installations
7. Handling and Shipping instructions

1. System components description

1.1 Septic tank

The septic tank must comply with state and local regulations. **Premier Tech Aqua (PTA)** can provide you with a complete line of high-performance polyethylene septic tank with size ranging from 600 to 1500 gal. See the Product Technical Guide for more information on these products and refer to the Septic Tank Installation Guide for Ecoflo® Biofilter for septic tank required specifications. The Ecoflo® Biofilter system comes with a concrete or a polyethylene septic tank.

1.1.1 PTA Effluent Filter EFT-080

The effluent filter extends the life of any treatment system by removing solids from the wastewater stream in the septic tank. An effluent filter is especially important in homes equipped with a garbage disposal, sewage pump or any other appliance liable to increase the suspended solids content of wastewater and thereby create premature clogging of the treatment system. An effluent filter will also prevent solids from reaching the effluent pump. The effluent filter **EFT-080** may also include a flow regulator adapted to the Biofilter capacity and a high water level alarm allowing detecting any backflow problem coming from the septic system.

The **PTA effluent filter EFT-080** is normally installed in the second compartment of the septic tank, but may also be installed, after the septic tank in a **PTA filter container TLF-240** in accordance with local regulation regulations. Please refer to our Product Technical Guide for more information on the **effluent filter EFT-080** and the **PTA filter container TLF-240**.

1.2 Ecoflo® Biofilters

The Ecoflo® Biofilter is a biofiltration system designed to treat domestic wastewater from a residential house. It is installed downstream of the septic tank. It can also be used to treat wastewater from commercial, communal and municipal projects. Please refer to the Commercial Design Guide for more information.

The **Ecoflo® Biofilter** collects and discharges treated effluent to an appropriate disposal method or into a watercourse, in accordance with existing regulations. Refer to **Appendix I** to evaluate the required model and the number of **Ecoflo® Biofilter** needed.

The **Ecoflo® Biofilters STB-650B and STB-650BR** are made of a watertight concrete shell. When site conditions permit, the effluent of the **STB-650B** model is evacuated at its base by gravity, while the effluent of the **STB-650BR** model is evacuated just below the surface of the ground with a pump integrated into the system.

These 2 models can treat the effluent from a residence of up to 4 bedrooms.

See the following table for a detail description of all the configurations of the system.

Ecoflo® Biofilters description	
STB-650B	Gravity effluent discharge (depending on site conditions)*
STB-650BR	Subsurface pressurized (pump) effluent discharge (depending on site conditions)
H _{1,2,3}	Height of the system (refer to tables on page 1 and 2 for dimensions)
A	Completely assembled system (assembled before delivery to the installation site)
NA	Not completely assembled system

*Important: Gravity effluent discharge is available only in the STB-650B-H1-A/NA configuration.

1.3 Pumping station (when required)

The pumping station is installed between the septic tank and the Ecoflo® Biofilter in the event that gravity flow is not possible. Like the septic tank, the pumping station must also be watertight to prevent groundwater infiltration. If the pumping station capacity exceeds 300 gal., Premier Tech Aqua recommends using a timed dosing unit TPA-300 to control the pump (see section 1.4 below). Premier Tech Aqua recommendation for the amount of water released to each Ecoflo® Biofilter is 8 to 10 gal. per dosing. Refer to the PSA-240 installation guide for more information.

1.4 Timed dosing unit TPA-300 (when required)

The TPA-300 or other acceptable timed dosing units control the release of wastewater to the Ecoflo® Biofilters (See TPA-300 installation guide). All commercial installation with 3 or more **Ecoflo® Biofilters** should be installed with a time dosing unit and an overall pumping totalizer, or with a flow meter.

Premier Tech Aqua has developed a complete line of associated equipment to achieve optimum performance of the Ecoflo® Biofilter or any septic system. For information on these products, see the relevant technical manual in this catalogue.

2. Components location and special instructions

Components of a residential septic installation (Ecoflo® Biofilter STB-650B/BR-H1/H2/H3-A/NA)

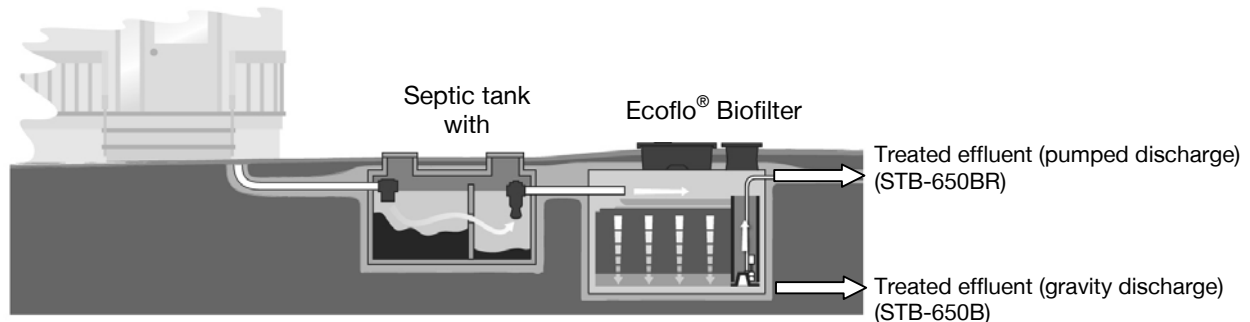

2.1 Installation conditions

2.1.1 Septic tank

The septic tank must be installed as specified by the septic tank manufacturer. The septic tank must be watertight, be used for disposal of domestic wastewater only (i.e. no roof water, surface water or discharge from footing drains), and be located in a place that is not subject to flooding or where the tank will not be submerged. The septic tank must be installed in accordance with the minimum clearance prescribed by local regulations.

2.1.2 Ecoflo® Biofilter

The access lid of the **Ecoflo® Biofilter** must be 2" aboveground after landscaping has been completed. **It is important that all involved parties (installer, landscaper, owner, snow removal company, etc.) be advised of the following:**

- Never cover or bury the access lids;
- Backfill should not exceed 20" over the top tile;
- Never overload the soil (e.g. vehicles, blown snow, embankments) within 6' of the lid;
- Ensure rapid revegetation to prevent soil erosion;
- Ensure that groundwater level never reaches the inlet invert of the **Ecoflo® Biofilter**;
- If a riser is required, only add a PTA **STR-080** riser to the **Ecoflo® Biofilter**. (see STR-080 installation guide).

3. Determination of the effluent disposal method

IMPORTANT! THIS STEP IS A CRUCIAL ELEMENT FOR ALL SEPTIC INSTALLATIONS

The Ecoflo® STB-650B/BR offers the choice of various disposal methods (according to local regulations):

Here are some proposed by Premier Tech Aqua:

Effluent from the Ecoflo® Biofilter STB-650B/BR can be discharged by gravity (STB-650B) or via an integrated pump (STB-650BR) towards:

- Subsurface discharge to a disposal method such as; trenches, bed, drip irrigation or any type of gravelless system;
- Discharge to a tertiary treatment system;
- Direct discharge into a watercourse or a ditch if this option is prescribed by local regulation.

3.1 Subsurface disposal

3.1.1 Hydraulic conductivity

An accurate assessment of the soil's hydraulic conductivity is a crucial step in planning any septic installation and should be performed in accordance with local regulation. The soil infiltration capacity is often expressed as a percolation rate, which can be determined by any qualified individual through a field permeability test, a laboratory soil particle-size analysis or any other method approved by the local regulation.

3.1.2 Soil absorption system

Once the soil characteristics have been established, the **soil absorption system or trenches** where the effluent will be disposed can be sized according to the **Appendix II** of this document. The soil absorption system must comply with the construction standards of local regulations.

The location of the absorption bed or trenches must comply with the setbacks prescribed by local regulations governing on-site wastewater treatment systems. If there is discrepancy between the **Appendix II** of this document and the local regulations for these specific products, the last-mentioned must prevail.

3.1.3 Required soil depth

Premier Tech Aqua's recommendation for the minimal vertical separation between the absorption bed and the limiting layer shall be 12" where no specific regulation is available.

Note: Always consider the following when building a polishing leach field:

- Soil's assessment must be performed in accordance with applicable regulations to determine the type of soil and limiting layer (rock, SHWT or clay);
- The above depth must be calculated using the **seasonal high water table** (SHWT) during the year;
- The profile of the lot must be such that surface runoff flows away from the septic system;
- The shape of the soil absorption system **may vary** according to site conditions;
- Various means can be used to promote seepage in low permeability soils. Contact your local Ecoflo® distributor or Premier Tech Aqua for suggestions.

3.1.4 Other type of disposal method

For other types of disposal system such as drip system, infiltration chamber or other gravelless type system refer to the product manufacturers catalog for their sizing and installation recommendations.

3.2 Discharging into a watercourse

The Ecoflo® Biofilter effluent may be discharged into a watercourse if in accordance with local regulations. The profile of the lot must ensure that surface runoff flows away from the septic system.

4. Functions of the Ecoflo® Biofilter STB-650B/BR

4.1 Components functions (see exploded view of the system on the following page)

Lids

- Give access inside the system (main and secondary access);
- Feed the filtering media with air (via air intake);
- Secure access with bolted assembly.

Insulating boards

- Give thermal insulation to the system;
- Helps guiding airflow into the shell's air ducts (main access only);
- Seal the system (with Premier Tech ty-wraps).

Shell (tank and top tile)

- Encloses the system components;
- Allows connection of air and water supply pipes;
- Holds the treated effluent;
- Circulates air to the filtering media's ends via its air ducts.

Central support plate

- Holds the tipping-bucket and one end of the distribution plates.

Support rails

- Hold the other end of the distribution plates.

Tipping-bucket

- Allows equal supply of influent on both sides of the filtering media;
- Creates hydraulic events required to obtain a good water distribution on the distribution plates and contributes to their self-cleaning.

Distribution plates

- Allow even distribution of the influent over the filtering media.

Filtering media

- Consists of a natural-fiber-based filter media;
- Acts as a support for bacteria that consume the wastewater organic content while trickling down through it.
- Does a physical filtration of the influent solids content.
- Keeps an adequate humidity level required for biomass viability when there is no incoming water.

Transportation netting

- Prevent filtering media to infiltrate the crushed stone during transportation (Assembled models only).

Treated effluent collection area

- Layer of clean crushed stone $\frac{3}{4}$ " \varnothing on the bottom of the shell;
- Supports the filtering media;
- Ensures drainage of the treated effluent;
- Ensures aeration under the filtering media.

Access funnel

- Encloses the pump equipment (for STB-650BR model);
- Allows air circulation between the top and the bottom of the filtering media;
- Allows inspection of the absorption bed;
- Allows access to the bottom of the system to collect treated effluent samples.

Aeration and drainage system

- Takes the effluent from the gravel bed and directs it towards the discharge pipe;
- Allows air circulation between the top and bottom of the filtering media;
- Gives storage capacity inside the Ecoflo® Biofilter (depending on the model) as required by local regulation.

Pumping unit (STB-650BR models only)

- Comprises a pump, a float tree, a ON/OFF float, an alarm float and an alarm box;
- Pumps the treated effluent towards a polishing field, a watercourse or a tertiary treatment system.

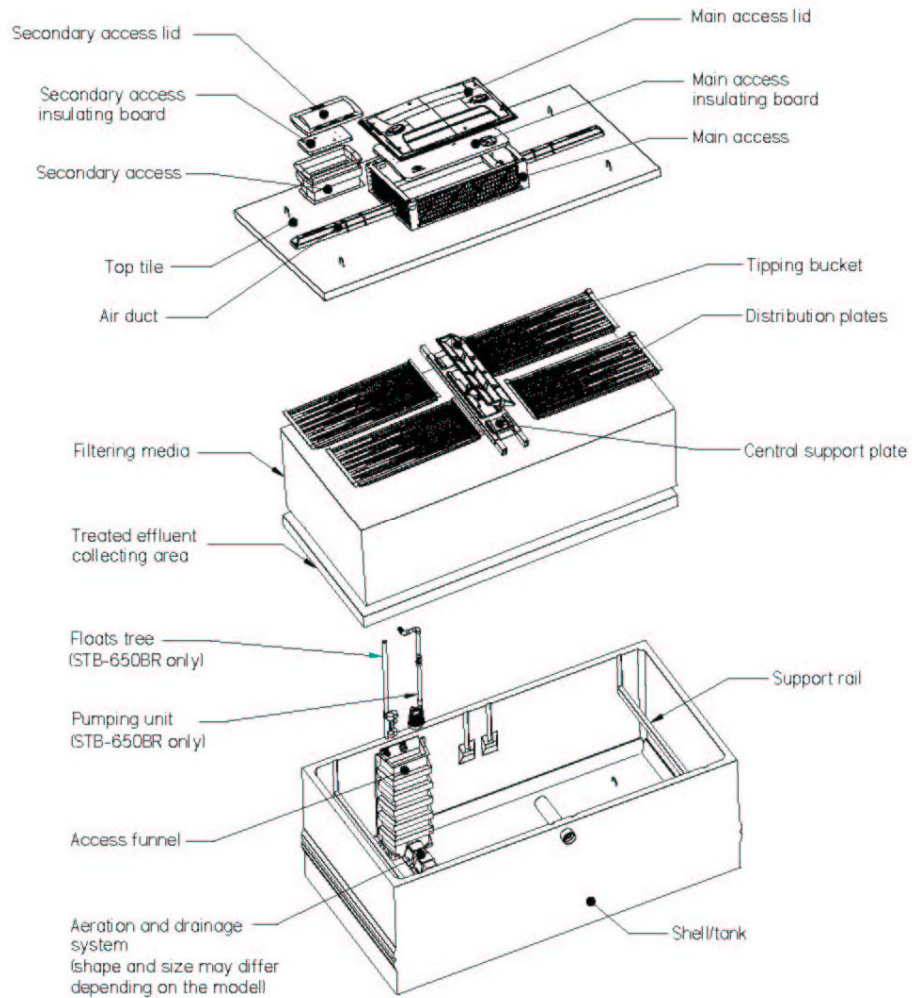

Exploded view of the system (model H1)

4.2 Global function of the system

The overall function of the **Ecoflo® Biofilter** is to treat domestic wastewater after a primary treatment. It is done via a water and air (oxygen) management inside the system. Wastewater is treated aerobically by bacteria fixed in the filtering media.

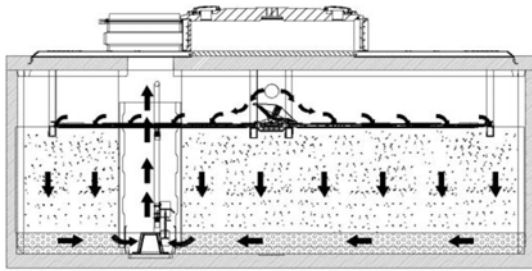

Water flow diagram
(STB-650BR with integrated pump)

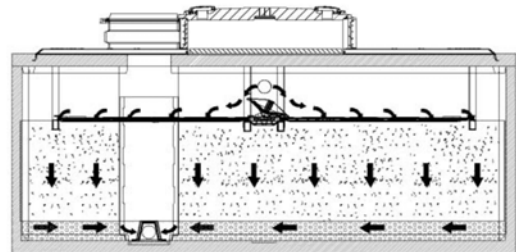

Water flow diagram
(STB-650B gravity discharged)

To be treated, the wastewater goes first into the septic tank where it is submitted to a primary treatment and then it enters into the **Ecoflo® Biofilter**. Once inside the **Ecoflo®**, the water is directed into the tipping bucket in order to be split equally over the distribution plates located on both sides of the central support plate. These plates include channels with orifices to distribute the influent evenly on top of the filtering media. Afterwards, wastewater trickles down into the filtering media where its organic content is consumed by bacteria. The treated effluent is collected in the gravel bed and evacuated by gravity (STB-650B) or with an integrated pump (STB-650BR).

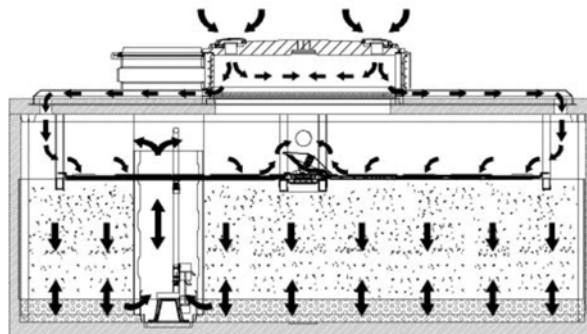

Airflow diagram

To be efficient, the system requires enough oxygen so that the filtering media's bacteria do their work. In order to achieve this goal, the filtering media is fed in oxygen by air flowing both at the top and the bottom of the filtering media. Air comes into the system by the intake located on the main access lid. Then, it goes to the extremities of the filter bed via the top tile's air ducts. Air flows at the top of the filtering media underneath the distribution plates, and enters the filtering media via the water infiltration that takes it to the bottom. Moreover, a gas exchange occurs at the top and bottom of the filtering media promoting its oxygenation. The opening located in the access funnel allows air circulation between the top and the bottom of the filtering media. Finally, the air circulation in the system is ensured by convection to the home air vent (or independent vent) via the inlet pipe and the septic tank.

5. Installation sequence

5.1 Make sure you have all the following components:

- A.** 1 concrete shell including:
- i 1 access funnel;
 - ii 1 aeration and drainage system
 - iii 1 inlet adapter 4" \varnothing ;
 - iv 1 outlet adapter cast in the concrete tank (non-illustrated):
For STB-650BR-H1-A/NA : 1" \varnothing ;
For STB-650BR-H2/H3-A/NA : 1½" \varnothing ;
For STB-650B-H1-A/NA: 4" \varnothing ;
 - v 1 bag (non-illustrated) containing the owner's documents, 4 black plastic ty-raps and 2 ty-raps marked "Premier Tech";
- B.** 1 top tile including:
- i 1 main access cast in concrete including an insulating board and a lid fixed with 4 lag screws;
 - ii 1 secondary access cast in concrete including an insulating board and a lid fixed with 4 lag screws;
 - iii 2 air ducts.

- C.** 1 pallet of filtering media
- D.** 1 central support plate;
- E.** 2 support rails in PVC;
- F.** 4 distribution plates;
- G.** 1 tipping-bucket;
- H.** Butyl seal;

Additional Items for model STB-650BR only (see sections 5.7 and 5.10 for items J to M):

- I.** 1 created outlet coupling 1" \varnothing for model H1, or 1½" \varnothing for models H2 and H3;
- J.** 1 coupling 1" \varnothing for model H1, or 1½" \varnothing for models H2 and H3, to connect the effluent discharge pipe to the disposal mean;
- K.** 1 pumping unit with a float tree installed inside the access funnel;
- L.** 1 alarm box;
- M.** 1 junction box with waterproof wire connectors.

Note: For models assembled before reaching the installation site, items Aii and H are not visible because of the presence of the filtering media.

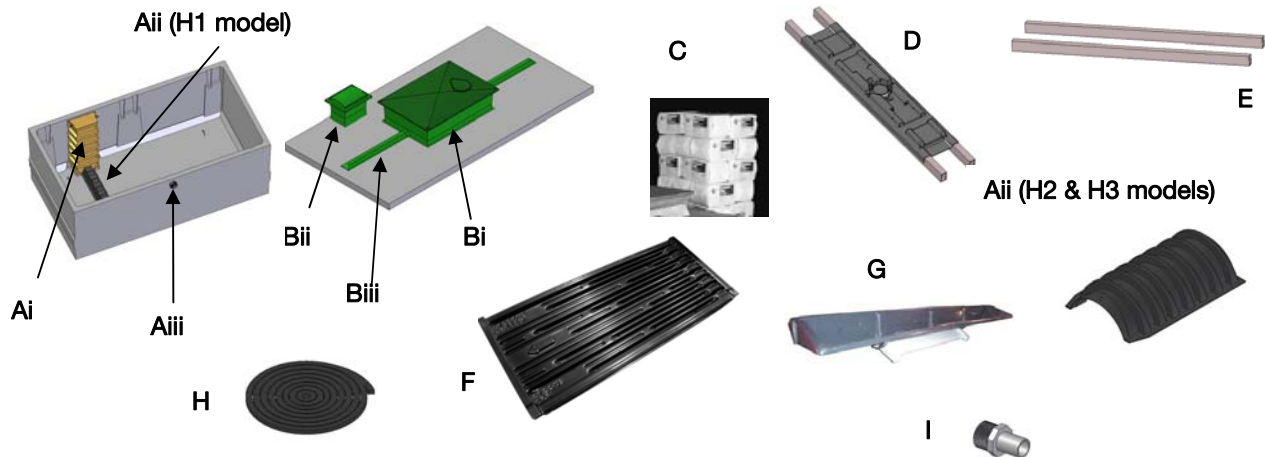

For any problem, broken or missing part,
contact our customer service at 1-800-632-6356

NOTE: The installer is responsible for all security measures applicable to all steps of installation including the use of hard hat, gloves, boots, glasses, mask, etc.

5.2 Excavation, foundation and system installation

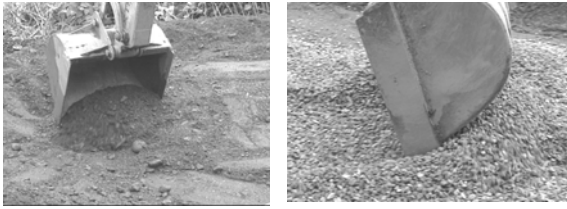

Excavate an area of about 10' x 15'. Depending on the soil conditions, it might be necessary to add a 6" layer of gravel Ø 0-¾" exempt of any vegetable matter, or a layer of clean crushed stone Ø ¾" surrounded by a geotextile. Set the shell down making sure that it is leveled and that its entire floor is in full contact with the foundation that has previously been compacted and leveled.

For the **Ecoflo® Biofilter STB-650B (discharged by gravity)**, connect the effluent discharge pipe, before going to the next step, using the flexible and watertight coupling. Connect the pipe to the **Ecoflo® Biofilter** making sure it is in a downward position all along its length towards the disposal area. Take note that the soil underneath the pipe must be well compacted.

5.3 Initial backfill of the shell

Take note that the height of the pipe inlet invert is different depending on the models as shown in the table below. Make sure that the groundwater highest seasonal level never reaches the level of the inlet invert.

Models	H1	H2	H3
Height of inlet invert (")	49 ¾"	56 ½"	68 ¼"

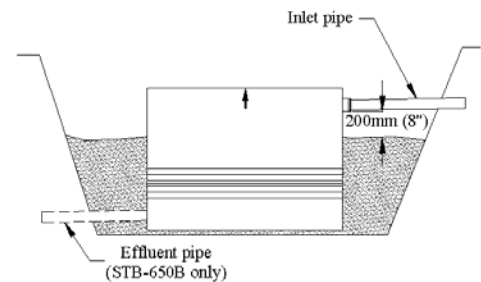

Model STB-650B/BR-NA

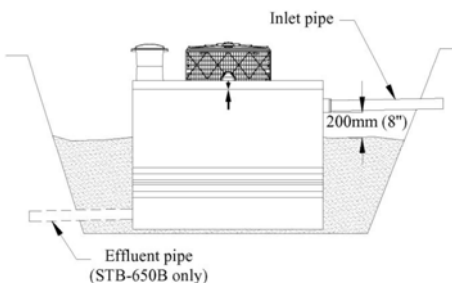

Model STB-650B3BR-A

Backfill the shell up to 8" under the inlet invert. When backfilling the shell, start by the two lateral sides and then backfill the two extremities. It is important that the backfill material be deposited, not dumped, which is why we do not recommend using a bulldozer for this step.

The backfill material should contain no organic matter, impermeable soil, stones, rocks, debris or other objects that could damage the shell.

ATTENTION: Make sure that no backfill material enters the shell when backfilling.

5.4 System assembly

5.4.1 Final leveling of the filtering media (Assembled models only)

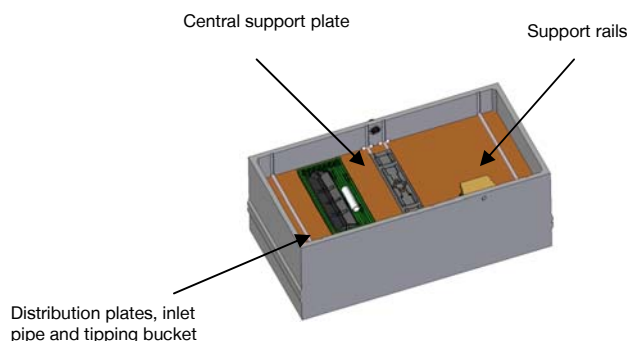

First, open the main access of the **Ecoflo® Biofilter**. Get inside standing on the central support plate and remove the distribution plates, the inlet pipe and the tipping bucket (that are tied together and laying on the filtering media) from the **Ecoflo® Biofilter** in order to make the final leveling of the filtering media. Make sure to carefully level the filtering media, even under the central support plate. After leveling the filtering media, put the components removed earlier back where they were (see sections 5.5 and 5.6 for their installation instructions).

ATTENTION!

- Make sure no backfill material enters the tank while moving inside.
- Make sure not to compact the filtering media (do not lean on it)
- Carefully level the surface of the filtering media.
- Make sure no filtering media enters the access funnel while leveling it.

5.4.2 Installation of the gravel and the filtering media (models not assembled only)

First inside the shell, spread a layer of clean crushed stone $\frac{3}{4}$ " (exempt of fine particles or organic debris) in the tank over the aeration and drainage system. Carefully level it. To determine the top level of the crushed stone layer, refer to the illustrations below depending on the model you are installing.

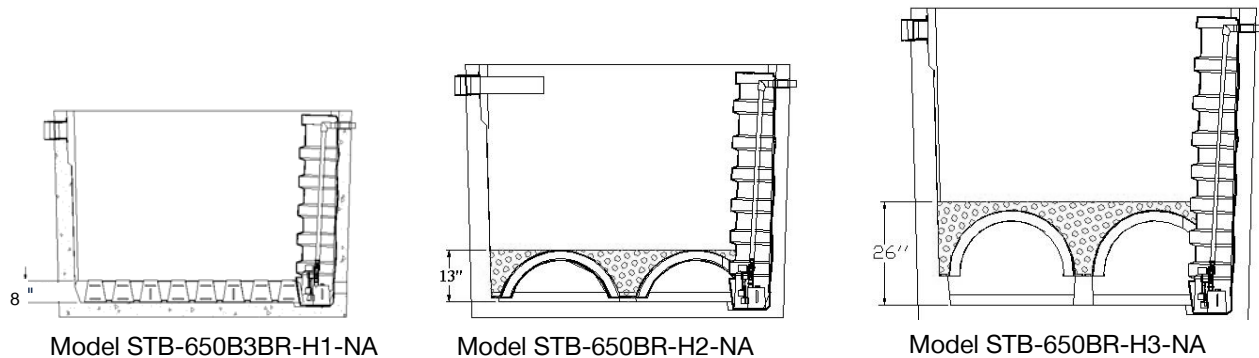

From the outside of the shell, pour the bags of filtering media. Level the surface (see illustration her). Clean the grooves of any particle, and place the support rails in the end grooves and the central support plate in the center groove. Finish pouring the filtering media up to the top of the support rails and level it with a rake.

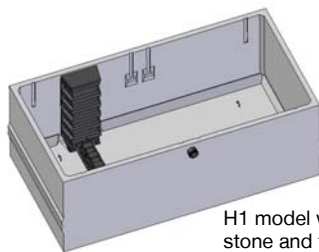

H1 model without the clean crushed stone and the filtering media

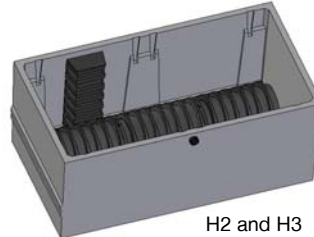

H2 and H3 models without the clean crushed stone and the filtering media

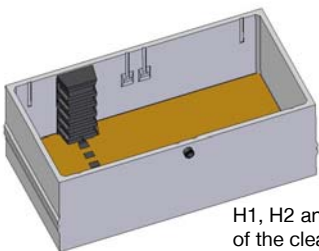

H1, H2 and H3 models with addition of the clean crushed stone (Model H1 illustrated)

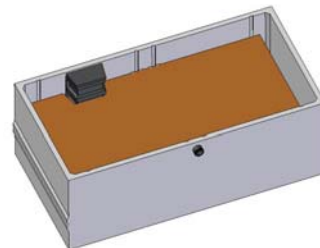

H1, H2 and H3 models with clean crushed stone and filtering media on top

ATTENTION!

- Make sure no backfill material enters the tank while moving inside.
- Make sure not to compact the filtering media (do not lean on it).
- Carefully level the surface of the filtering media.
- Make sure no filtering media enters the access funnel while pouring it.

5.5 Installation of the distribution plates

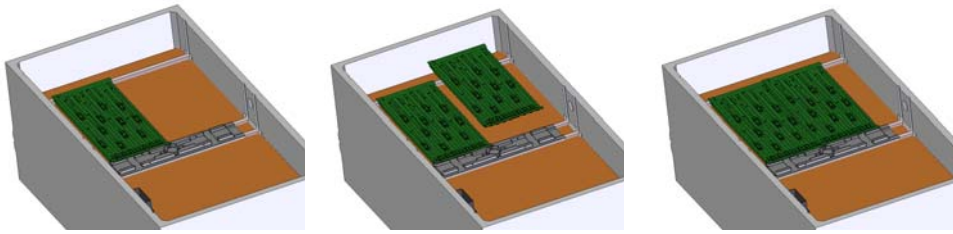

- Install the distribution plates by placing them on the support rails at the ends;
- The arrow on the distribution plates must be oriented toward the end of the tank;
- Place the first plate on the left end side and set the second one on the edge of the first one;
- Repeat on the right side of the tank (2 plates on each side of the tank).

The distribution plates sit on top of the central support plate and must be attached to it with the four plastic ty-raps.

5.6 Tipping-bucket and inlet pipe installation

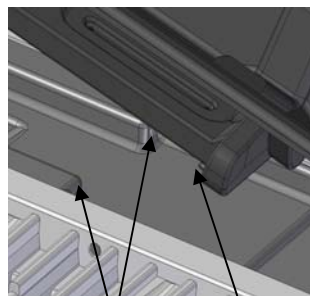
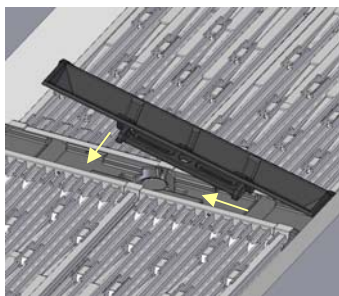

Anchor slots locking catch

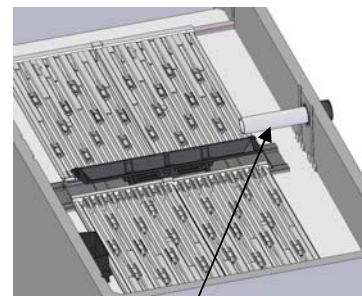

Inlet pipe (interior part)

Once the distribution plates are in place, install the tipping-bucket by inserting its locking catches in the anchor slots of the central support plate and set the other end down in secure position. Then, glue the interior part of the inlet pipe in the water inlet of the shell.

5.7 Inlet and discharge pipe connections

Connect the inlet pipe (coming from the septic tank) to the **Ecoflo® Biofilter** inlet making sure that the pipe is in a downward position towards the Biofilter all along its length. Take note that the soil underneath the pipe must be well compacted.

The **Ecoflo® Biofilter** is equipped with a standard flexible inlet adapter. The connection is made with a regular pipe clamp.

The STB-650BR effluent must be connected to the treated effluent disposal mean (watercourse, polishing field or tertiary treatment system) by a 1" \varnothing or a 1½" \varnothing flexible pipe that can support a pressure of at least 100 psi and consistent with underground applications. A 1" \varnothing or a 1½" \varnothing crenated coupling (**Item I**) links this flexible pipe to the Biofilter outlet. The other end of the pipe is connected to the treated effluent disposal mean via the coupling supplied for (**Item J**). Precautionary measures against freezing must be taken if discharged to a watercourse.



ATTENTION!

The inlet pipe invert must be at all times higher than the groundwater level. If the terrain layout makes it that surface run-off accumulation is possible, a drain pipe must be added to evacuate the excess water and prevent any risk of infiltration. The pipes must be placed in a manner that gravity can drain them

5.8 Access funnel opening

In model **STB-650B**, the main function of the access funnel is to allow air flow between the top and the bottom of the system. In model **STB-650BR** the access funnel is also used as a pump vault. The lid of the access funnel is there to prevent gravel or particles of filtering media to fall into this access during installation. Therefore, after the installation of the filtering media, remove the lid (**taking care not to let the ty-raps fall inside the funnel**) and **do NOT put the lid back on**.



5.9 Top tile installation (models not assembled only) and final backfill of the system

Attention! The top tile must be installed before finishing to backfill.

Clean the rim of the tank properly to lay the butyl seal. To provide complete watertightness, the seal must be laid in one continuous section. The junction point between the two ends of the seal must be done as shown below. Proper cleaning of the inside of the top tile is required to insure watertightness and so no backfill material enters the filtering media.

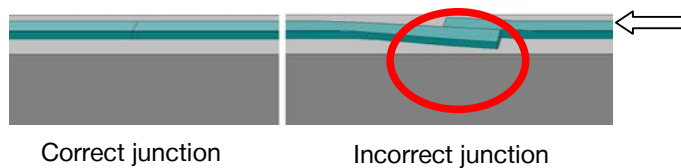

Once the butyl seal is laid, set the top tile on the tank being careful to align the secondary access with the access funnel.

Complete the backfill by complying with the indications provided in sections 5.2 and 5.3 (soil underneath the pipes should be compacted and we don't recommend using a bulldozer for backfilling). Allow space for plant cover and make sure that the lids exceed the finished landscape by 2".

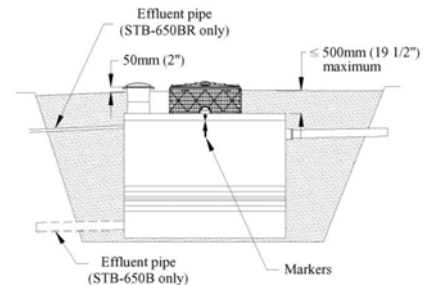

The usual burial depth is 12". If necessary, you may add **one (maximum) 20 cm (8") extension kit STR-080** on the **main and secondary accesses**. **The maximal burial depth is 20" over the top tile.**

Before backfilling model **STB-650-BR**, do not forget to connect the power supply of the pump (see next section).

5.10 Pump verification and electrical wiring for model STB-650BR only (with integrated pump)

Step 1 Pump verification

Perform a visual inspection of the components inside the access funnel (pump, float tree, floats) to make sure they are installed and will work properly.

Step 2 Electrical wiring

All electrical connections must be done by a certified electrician. To wire the system to the residence, 2 in-ground double strand supply cables are required. It is preferable to protect the wires to be buried with the appropriate piping. The wire rating must also be done by a specialist in the field. One of the wires will be used for the power supply line and the other one will bring power from the alarm float to the alarm box. The use of waterproof connectors is required since they pass through the secondary access. In fact, the wires must enter the secondary access under the structural rib. Use the reference point on the access to locate the right place.

Execute the appropriate electrical wiring using the items supplied for: junction box and waterproof wire connectors. First, remove the plugs off the wires by cutting off 2" from the pump and float wires. The junction box is located in the secondary access on the insulating board. Identify and insert the wires in the junction box as indicated on the diagram. Use the waterproof wire connectors to make sure that water will not affect the electric circuit. Follow the color coded diagram. Then close the junction box. Pass the wires coming from the pump through the slot in the insulating board. Place the insulating board in the access with the electrical box on top and put the access lid on.

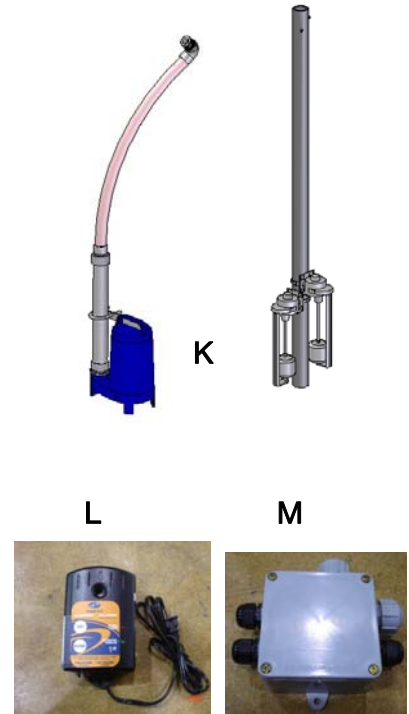

Note: the electrical connections for the pump and the alarm box must be performed on two separate electric circuits.

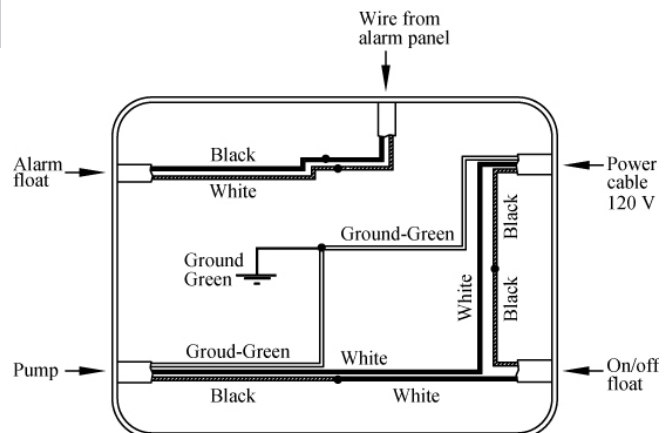
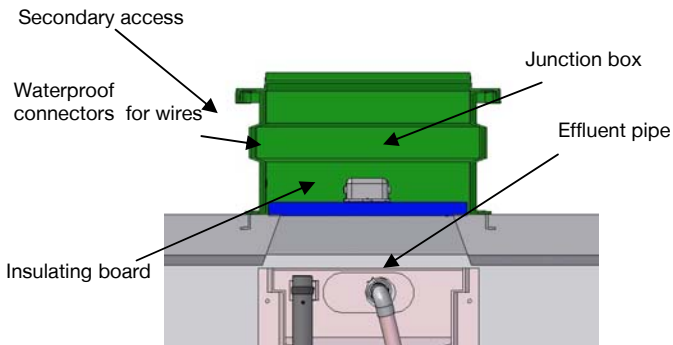

Step 3 Float adjustment and verification

The floats are pre-adjusted in order to give the dose volume described hereunder. These pre-adjustments should fit for most of the applications.

Models	Maximum dose volume (gal.)	Volume in outlet pipe (gal/ft of pipe)		
		1" Ø	1½" Ø	2" Ø
STB-650BR-H1-NA	25	0.04	0.09	0.16
STB-650BR-H2-NA	See Table below			

However, the following table and figures indicate the **dose volume obtained related to the On/Off float adjustment for the STB-650BR-H2/H3**. There is **no adjustment possible with the STB-650BR-H1 model**.

STB-650BR-H2/H3			
Float adjustment			Dose volume (gal)
A	B	C	H2/H3**
11 ¼"	2 1/2"	2 ¾"	30
		*3"	50
		4"	85
		5"	120

*The ON/OFF float is pre-adjusted to obtain this volume.

** Values may varie.

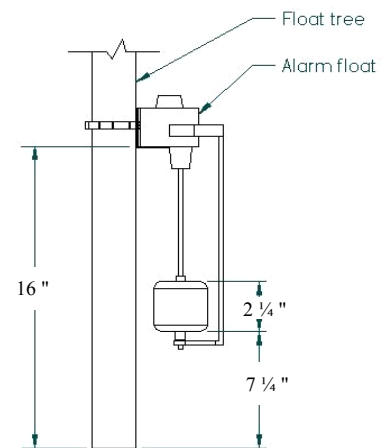
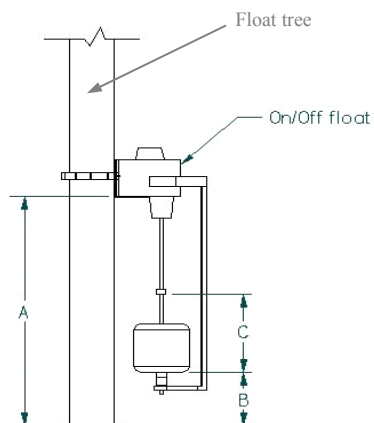

PERFORMANCE CURVES OF PUMP MODELS H1, H2 and H3

Two different pumps are available depending on the model of Biofilter installed. The diagrams below presents the performance curves of the pumps supplied with the **Ecoflo® STB-650BR**. Note that these curves have been achieved with clean water; the pump's performance could be lower with wastewater. If you have any question concerning the reading of this curve, do not hesitate to contact Premier Tech Aqua.

Pumps characteristics

- 0.3 HP
- 6.2 amps
- 1Ø, 60 Hz, 115 V

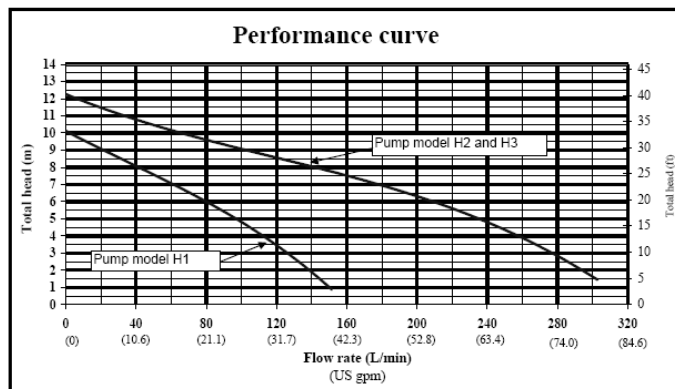

5.11 System operation verification and sealing



After making sure the distribution system operates properly, close the **Ecoflo® Biofilter** by installing first the insulating board and then the lid. Seal it shut by attaching the handle of the insulating board to the access of the **Ecoflo® Biofilter** using the two plastic seals.

Do not forget the municipal inspection when required.

Checkpoints following installation:

- Never cover or bury the access lid.
- Never plant trees within 16.4' of the **Ecoflo® Biofilter** lid and within 6.5' of the absorption bed.
- Never open or enter the **Ecoflo® Biofilter** after installation without prior authorization.
- Never connect a drain pipe, roof gutter, sump pump or air conditioning drain to the septic installation.
- Never drive vehicles or place objects weighing over 500 lb within 10' of the lid**, and if you plan to do any landscaping, make sure you advise those involved so they don't damage your septic system.
- In case of a lapse of time between the initial installation and final landscaping, identification and protective barriers should be placed to identify the unit, to keep traffic off the unit, and to indicate the final level of the installation.**
- It is possible to add a riser on the system's access. The maximum distance between the top of the top tile and the top of the accesses is 20". Use ONLY ONE (1) PTA's extension kit STR-080/ STR-080SP.**
- Do not let anything accumulates on top of the septic system (ex. blown snow).
- The home must be equipped with an air vent that is in proper working order and complies with the applicable standards; **Premier Tech Aqua** strongly recommends using a 4" Ø pipe.
- Give the owner the plastic bag containing the *Owner's Manual and the Maintenance Agreement*.
- Mention to the customer to fill out and sign the *Maintenance Agreement*. He is to keep the white copy, send the yellow copy to the municipality (when required) and the pink copy to the **Premier Tech Aqua**.

**FOR ANY PROBLEM, QUESTION OR COMMENT,
DO NOT HESITATE TO CONTACT OUR CUSTOMER SERVICE AT
1 800 632-6356**

6. Typical installations

The type of installation depends on the site constraints. Here are some examples.

Type 1: Installation on flat grounds with effluent discharged by gravity (model STB-650B)

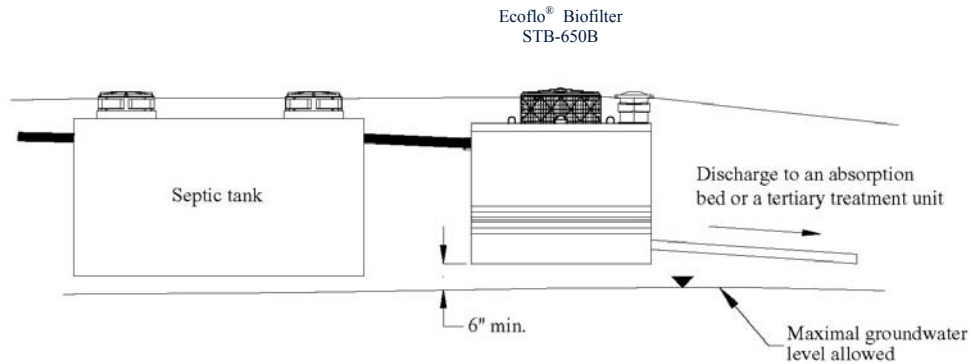

Type 2: Installation on flat grounds with an integrated pump (STB-650BR)

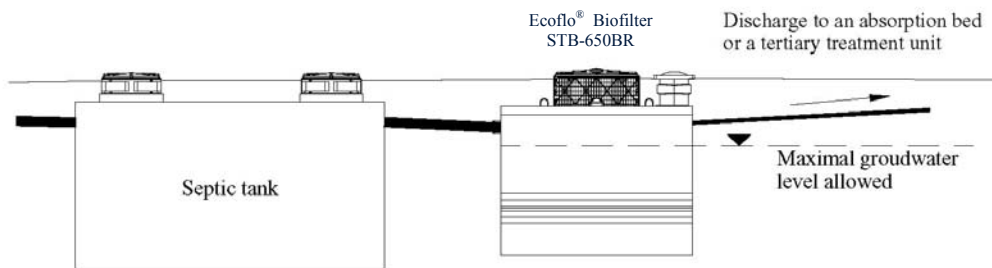

Type 3: Installation with effluent discharge pumped into a watercourse (if in accordance with local regulations)

It is possible, if the watercourse level is higher than the bottom of the shell, that a siphon effect happens and causes a backflow inside the **Ecoflo® Biofilter**. A depressurization vent will then be required at the point connecting the pressurized pipe (1" \varnothing or 1½" \varnothing flexible) with the gravity pipe (DR 35 4" \varnothing) conveying the wastewater to the watercourse.

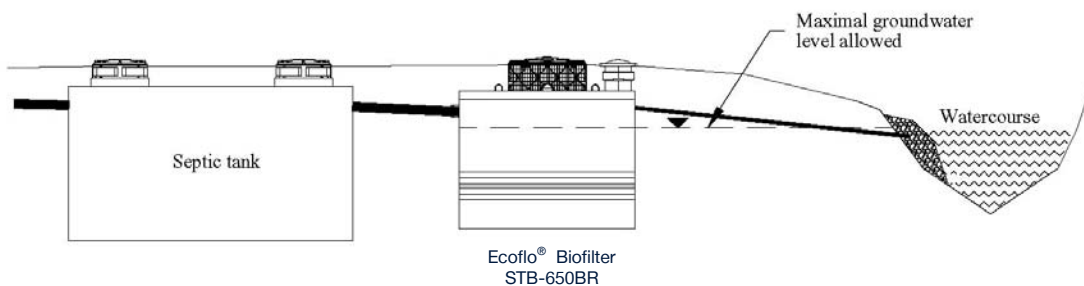

**Type 4: Installation with effluent discharged by gravity into a watercourse
(if in accordance with local regulations)**

The watercourse highest seasonal level must be considered so the bottom of the shell is never submerged.

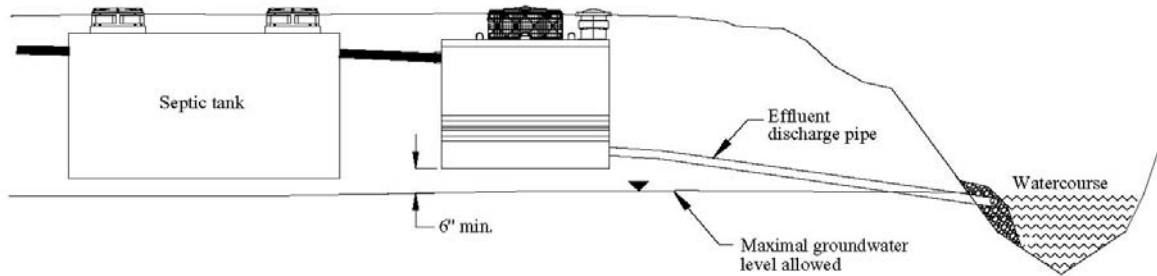

Type 5: Installation of 2 Ecoflo® fed by gravity and discharged by gravity (STB-650B-H2 models only)

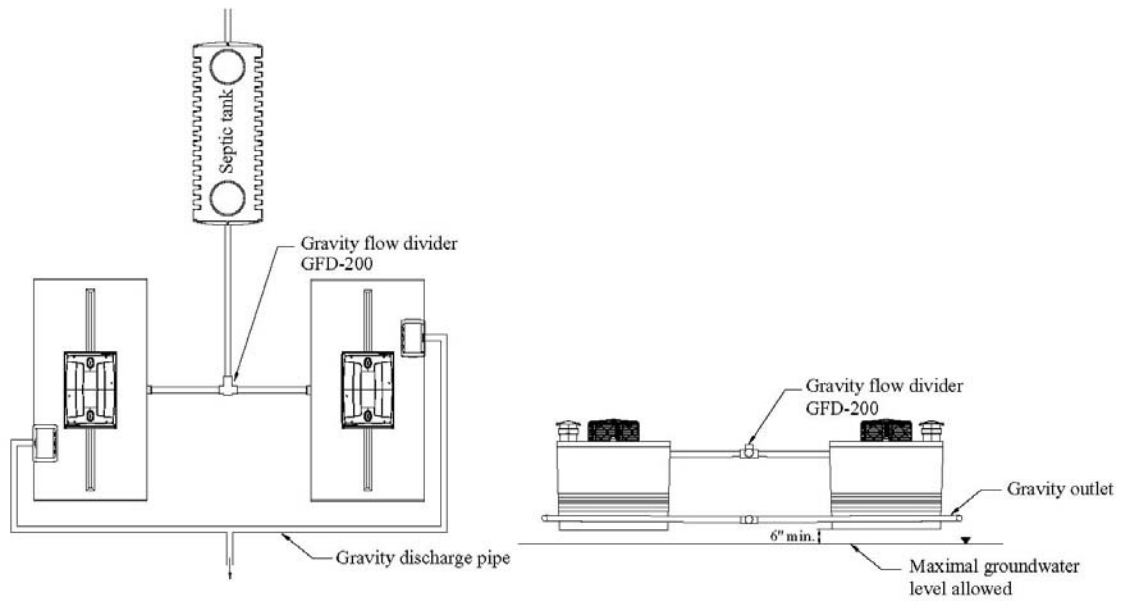

Very important: The Ecoflo® modules must be at the same level ($\pm \frac{1}{2}$ in)

**Type 6: Installation of 2 Ecoflo[®] fed by a gravity and discharged by an integrated pump
(1 STB-650B-H2 combined with 1 STB-650BR-H2)**

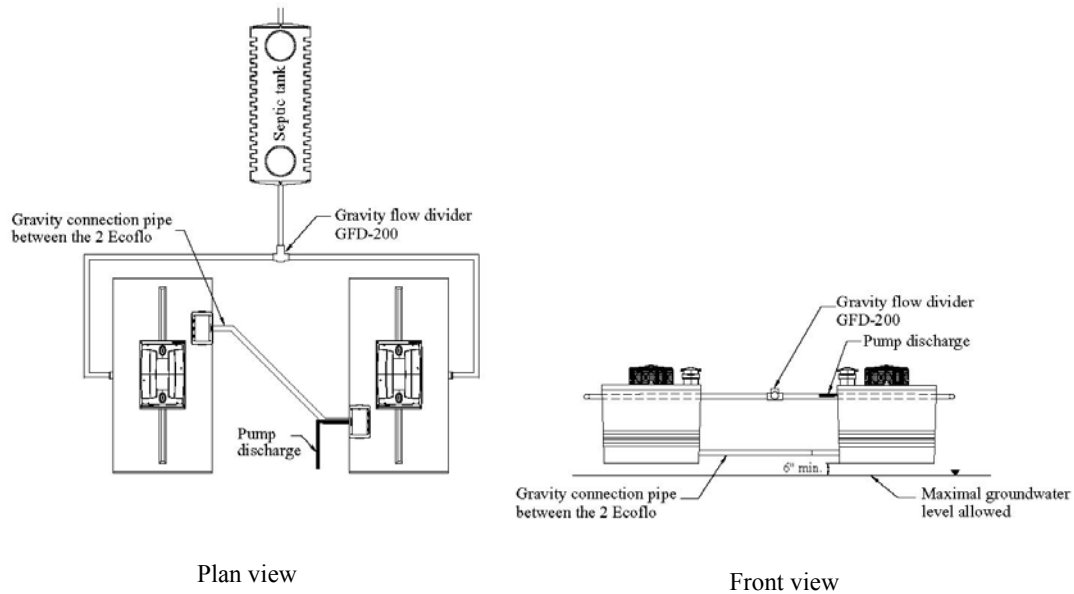

Very important: The Ecoflo[®] modules must be at the same level ($\pm 1/2$ in)

**Type 7: Installation of 2 Ecoflo[®] fed by a pump and discharged by gravity
(STB-650B-H2 models only)**

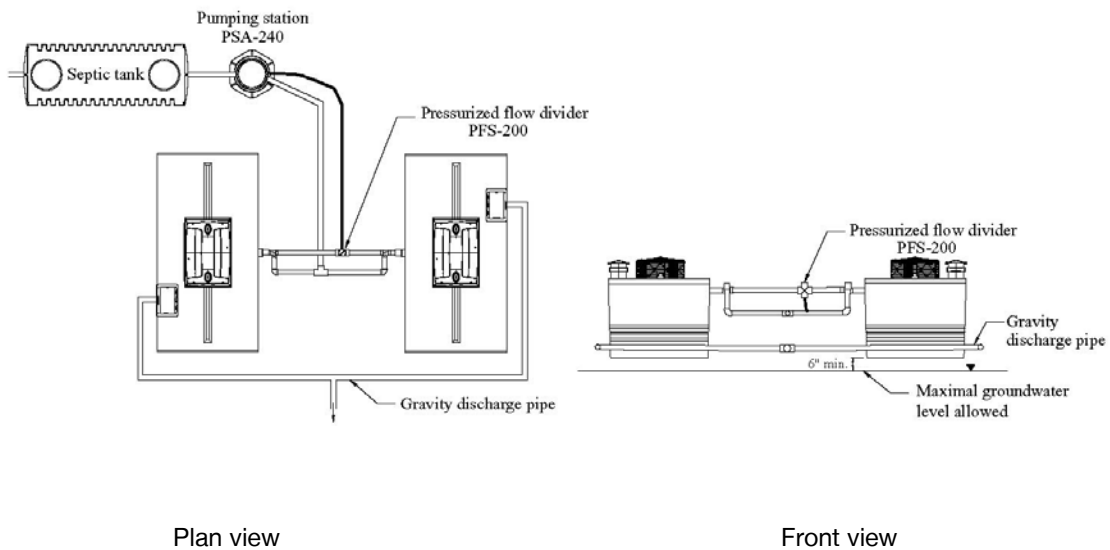

Very important: The Ecoflo[®] modules must be at the same level ($\pm 1/2$ in)

**Type 8: Installation of 3 Ecoflo® fed by a pump and discharged by gravity
(STB-650B-H2-NA models only)**

Notes:

- It is possible to use a PSA-240 pumping station to feed up to 3 Ecoflo® Biofilters maximum;
- The ground water level must not exceed the flow divider base level and the inlet level of the Ecoflo® Biofilter.

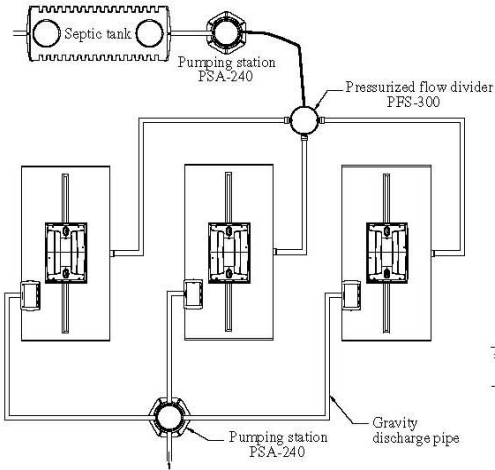

Plan view

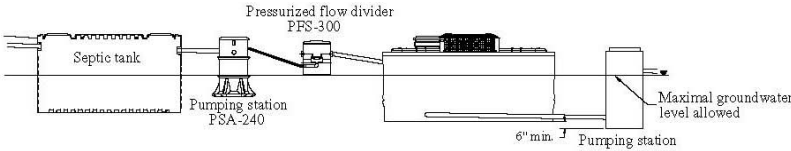

Front view

Very important: The Ecoflo® modules must be at the same level ($\pm 1/2$ in)

7. Handling & Shipping instructions

7.1 Shipping from the dealer to the installation site of the Ecoflo® Biofilter STB-650B/BR

- Use a vehicle with loading space wide enough for the **Ecoflo® Biofilter** to fit in completely.
- The vehicle must also be capable of moving the **Ecoflo® Biofilter** once on the installation site.
- Secure the Biofilter to the vehicle with appropriate straps.
- The carrier is responsible for any damages and for the observance of traffic regulations.

7.2 Handling

- The concrete shell and the top tile can be handled together or separately.
- Nobody should be inside the Biofilter during handling.
- To handle the shell and the top tile together, use the lifting grooves and chains on both ends of the shell.
- To handle the shell and the top tile separately, use the anchor rings or the lifting grooves.
- When using the anchor rings, make sure to use the 4 rings and chain sections of the same length.
- Material handler is responsible for any damages caused by him.

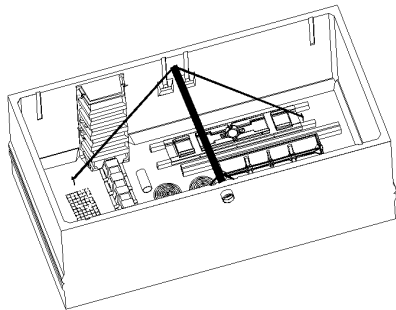

STB-650B/BR-H1-NA models

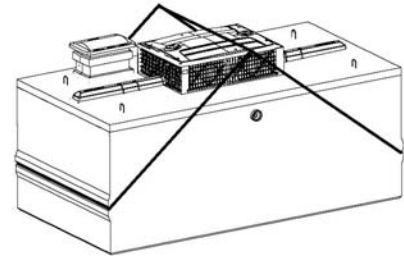
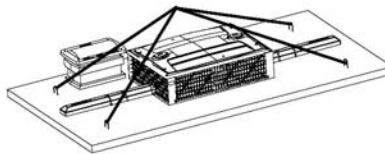

STB-650B/BR (all models)

Handling diagrams for the Ecoflo® Biofilter STB-650 B/BR

7.3 Loading configuration

- The loading configuration depends on the type of vehicle used to transport the Biofilters to the installation site.
- The loading area must be at least 12'6" x 6'7" for all models of **Ecoflo® Biofilters** to fit in completely.
- The carrier must keep enough space to transport the filtering media bags (bags can be taken off the pallet). A pallet of filtering media bags measures about 4'10" x 3'10" (STB-650B/BR-NA models only).



1 800 632-6356
418 862-6642
pta@premiertech.com
PREMIERTECHAQUA.COM

The information contained in this document is based upon the latest information available at the time of publication and is designed to provide you with a general introduction to our products. We make no warranties or representations as to its accuracy. We are continually updating and improving our products and reserve the right to amend, discontinue, alter or change specifications and prices without prior notice. Ecoflo® is a brand of Premier Tech Ltd. The Ecoflo® Biofilter is protected under patents: Canada 2 149 202, 2 022 097 and 2 499 637, USA 5 618 414, 5 206 206, 7 097 768 and 7 790 035 and Europe 0 836 585 and 1 539 325.

© Premier Tech Ltd, 2011